

HMS INDUSTRIES

UCX200-SERIES Set Screw Type - Medium Duty

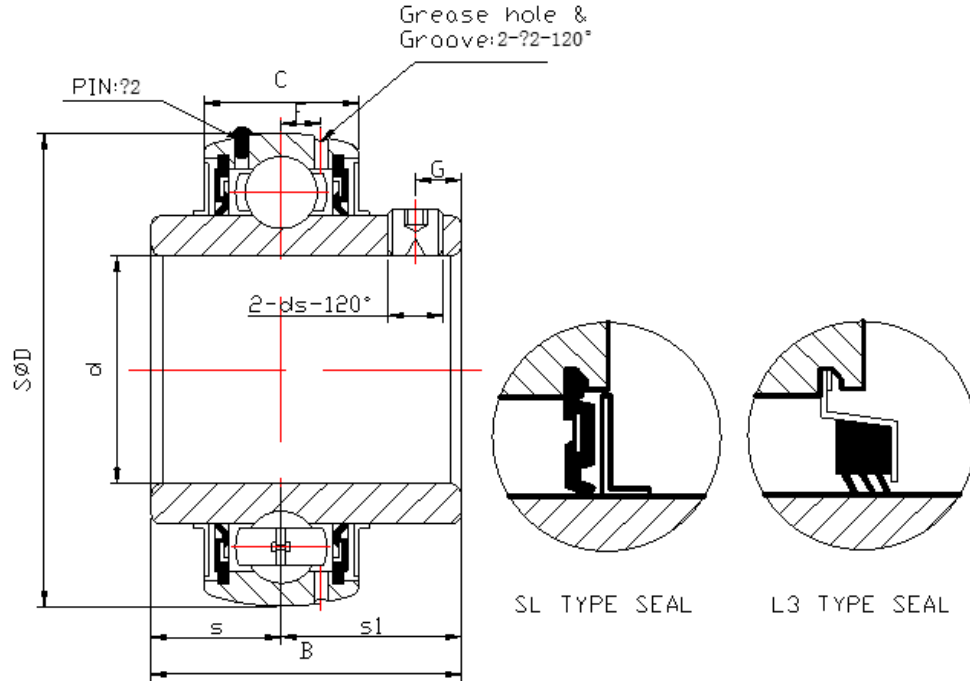

HMS Bearing No.	Bore (d)		Dimensions ^{in, mm}								Dynamic Load Ratings(N)	Static Load Ratings(N)	Weight (kg)
	(in)	(mm)	D	B	C	S	S1	G	ds	F			
UCX05-13	13/16		2.4409	1.5000	0.7480	0.6260	0.8740	0.1969	1/4-28UNF	0.2165	19500	11300	0.39
UCX05-14	7/8												
UCX05-15	15/16												
UCX05-16	1												
UCX05		25											
UCX06-17	1-1/16		2.8346	1.6890	0.7874	0.6890	1.0000	0.2756	5/16-24UNF	0.2165	25700	15300	0.68
UCX06-18	1-1/8												
UCX06-19	1-3/16												
UCX06-20	1-1/4												
UCX06		30											

UCX07-20	1-1/4		3.1496 80	1.9370 49.2	0.8268 21	0.7480 19	1.1890 30.2	0.3150 8	5/16-24UNF M8*1.0	0.244 6.2	29500	18100	0.82
UCX07-21	1-5/16												
UCX07-22	1-3/8												
UCX07-23	1-7/16												
UCX07		35											
UCX08-24	1-1/2		3.3465 85	1.9370 49.2	0.8661 22	0.7480 19	1.1890 30.2	0.3150 8	5/16-24UNF M8*1.0	0.252 6.4	31600	20600	0.93
UCX08-25	1-9/16												
UCX08		40											
UCX09-26	1-5/8		3.5433 90	2.0315 51.6	0.9449 24	0.7480 19	1.2835 32.6	0.3937 10	3/8-24 M10*1.25	0.256 6.5	35000	23200	1.00
UCX09-27	1-11/16												
UCX09-28	1-3/4												
UCX09		45											
UCX10-29	1-13/16												
UCX10-30	1-7/8		3.9370 100	2.1900 55.6	0.9843 25	0.8740 22.2	1.3150 33.4	0.3937 10	3/8-24 M10*1.25	0.276 7.0	43500	29200	1.35
UCX10-31	1-15/16												
UCX10-32	2												
UCX10		50											
UCX11-32	2		4.3307 110	2.5630 65.1	1.0630 27	1.0000 25.4	1.5630 39.7	0.3937 10	3/8-24 M10*1.25	0.335 8.5	47700	32900	1.90
UCX11-33	2-1/16												
UCX11-34	2-1/8												
UCX11-35	2-3/16												
UCX11		55											
UCX12-36	2-1/4		4.7244 120	2.5630 65.1	1.1024 28	1.000 25.4	1.563 39.7	0.394 10	3/8-24UNF M10*1.25	0.335 8.5	57500	40000	2.27
UCX12-37	2-5/16												
UCX12-38	2-3/8												
UCX12-39	2-7/16												
UCX12		60											